

PSR-630 ProxLock Stand-Alone Proximity Access Control System

GENERAL DESCRIPTION

The ProxLock (PSR-630) is a low cost stand-alone programmable access control system based on the GSC proximity tags and cards.

The read-head, electronics, memory and relay circuitry are contained in a robust plastic housing allowing for simple installation. The minimum connection only requires AC or DC power and a door strike.

The standard unit can store the codes of 120 unique tags. Optionally, units can be provided to store up to 500 and 2000 tag codes.

Adding and deleting tags is done by simple use of a Master Tag.

The optional Tag Simulator / Programming Unit allows the programming (adding & deleting) of lost tags.

The unit may also be set for *Pulse* mode (the relay operates for a pre-set time for each valid tag read) or *Toggle* mode (the relay state changes for each valid tag read).

The optional Remote Read Head is suitable for installations where a separate tamperproof and waterproof read head is required. This makes a secure system by allowing the control electronics and relay to be mounted in a dry, secure area away from the read-head coil.

The Remote Read-Head also acts as a second reader point and is suitable for installations where a read-head is required on both sides of the access point.

The optional ProxLog logging module and Windows software allows transaction logging with date and time.

Normal Operation (Run State)

The ProxLock has two states, Programming and Run. The Run state is the normal operating state of the ProxLock and the operation depends on the Mode selected at installation time. The Programming state is explained in the next section.

Run State - Pulse Mode

In this state, the YELLOW lamp is always on and the GREEN and RED lamps are off.

Whenever a valid tag is read, the GREEN lamp will go on and the relay will operate, for the pre-set Relay Pulse time.

If a card is not recognised the RED lamp will go on for 1.5 seconds.

Run State - Toggle Mode.

On power-up, the YELLOW and RED lamps will be on and the relay will be off.

Whenever a valid tag is read the GREEN and RED lamps will change state.

While the GREEN lamp is on and the RED lamp is off, the relay is energised (the NO contact will be closed). When the GREEN lamp is off and the RED lamp on, the relay is not energised (the NO contact will be open).

Programming

The Master Tag is the first tag presented to the ProxLock when it is in the Add Master state. All programming is done by using this Master Tag.

To select a program function:

Make successive reads of the Master Tag (each read must be no more than 2 seconds apart).

Each read of the Master Tag sets the ProxLock to a new programming function.

Once the required function has been reached, wait for the lamp to start flashing, (approximately 3 seconds), indicating that the ProxLock is now in the selected function.

Add Master Tag

If the RED, GREEN and YELLOW lamps are flashing, it indicates that the memory is empty and that there is no Master Tag.

In this state the first tag read will be stored as the Master Tag.

Add Tags

To select this function:

1. Read the Master Tag once.
2. Only the GREEN lamp will light.
3. Wait for the GREEN lamp to start flashing.

The ProxLock is now in the ADD state.

In this state every tag that is presented to the reader will be stored in the system memory. (Tags can now also be added by using the optional Tag Simulator.)

If a large number of tags have to be added, the ADD-ON-THE-RUN method can be used by leaving the

ProxLock in the Add Tags state. In this state every tag presented to the ProxLock will open the door and be added to memory.

Once all the required tags have been presented, read the Master Tag to return to the RUN state.

Delete Tags

To remove a tag from the system, that tag must be available or the Tag Simulator must be used. If these are not available, the system memory must be cleared and all valid tags re-added.

To select this function:

1. Read the Master Tag twice with a time between reads of less than 2 seconds.
2. The RED lamp will light.
3. Wait for the RED lamp to start flashing.

The ProxLock is now in the DELETE state.

In this state every tag that is presented to the reader will be deleted from the system memory. (Tags can now also be deleted by using the optional Tag Simulator.)

Once the tag or a group of tags have been deleted, read the Master Tag to return to the RUN state.

Clear Memory

To delete all the tags from the memory including the Master Tag and Strike time, place the unit in the CLEAR MEMORY state.

1. Read the Master Tag three times with a time between reads of less than 2 seconds.
2. The GREEN and RED lamps will light.

3.Wait for the GREEN and RED lamps to start flashing.

The ProxLock is now in the CLEAR MEMORY state. Now present any tag except the Master Tag to the reader and all memory will be cleared.

Alternatively, read the Master Tag to abort this function.

Once the memory is cleared the YELLOW, GREEN and RED lamps will flash to indicate that the memory is empty.

Time Adjust (Pulse Mode Only)

This function sets the relay operating time for a push-button input and a valid card read.

To select this function:

- 1.Read the Master Tag 4 times with a time between reads of less than 2 seconds.
- 2.All the lamps will go off.
- 3.Wait for the YELLOW lamp to start flashing.

The ProxLock is now in the TIME ADJUST state and each flash of the YELLOW lamp equates to 0.25 seconds of relay operation time.

For example, to set a time of 1.5 seconds:- read the Master Tag - allow the YELLOW lamp to flash 6 times - read the Master tag again.

Once the desired time is reached, read the Master Tag to store the time and return to the Run state.

CONNECTION DIAGRAM

Typical connections for the PSR-630 are shown below.

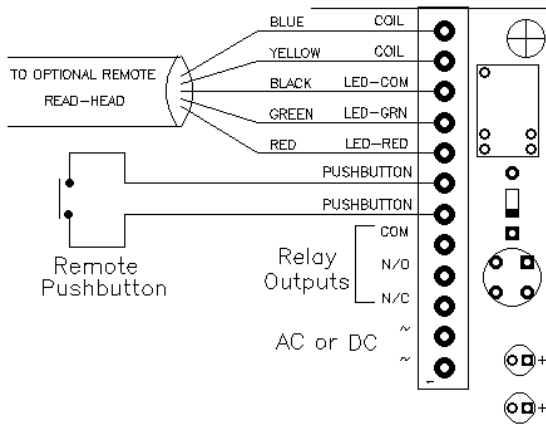

Typical strike connections are shown below.

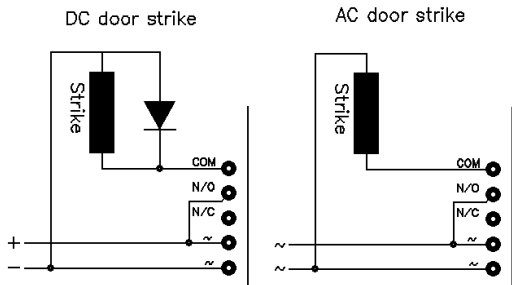

INSTALLATION

POWER

Connect 8-12V AC or 10-14V DC to the two terminals marked ~. The polarity of the connection is not important.

DOOR STRIKE

The unit provides a relay output rated at 24 VDC at 1A . The following contacts, that are isolated from the rest of the board, are provided; normally open (NO) contact, normally closed (NC) contact and a common (COM).

Typical connections to a door strike are shown on the drawing.

Note: When using a strike with DC, the relay contacts will be damaged by arcing due to back EMF when the contact opens. Use a IN4001 diode as shown on the drawing to prevent this damage.

Push-button

A push-button may be connected to allow remote operation of the door strike relay in the same manner as if a tag is read.

The push button must be normally open and is wired between the two PUSH-BUTTON connections on the reader base.

Remote Read-Head (Optional)

There are 5 connections to the Remote Read-Head, 2 for the sense coil and 3 for operating the 2 indicator lamps.

Connect as shown in the drawing.

The cable length may be increased to 10 metres with a loss in reading range. Longer cable lengths may cause reading problems.

The Remote Read-Head has only RED and GREEN indicator lamps and is therefore not suitable for programming. This must be done on the main unit.

The Remote Read-Head must be mounted a minimum of 20mm above metal .

Position

The ProxLock works on the principle of radiating a magnetic field from a coil.

The field generated by the coil will be affected by the close proximity of metal.

Ideally ProxLock should be mounted on non metallic materials. If the unit is mounted on a metal surface the reading distance will be reduced. (approx. 70 %)

Multiple ProxLocks

The radiated field of the ProxLock coil extends in all directions including through brick walls. The coil of one ProxLock will interfere with another if they are mounted within 400mm of each other.

Jumpers

To gain access to the configuration jumpers, undo the 2 retaining screws on the front cover and carefully lower the cover. The jumpers are on the board attached to the cover.

The unit is normally supplied with the MODE jumper **on** (PULSE mode)

These pins are connected directly to static sensitive electronics.

Avoid direct contact with the jumper pins.

Clear SYSTEM Memory

To clear the system memory, remove power and short the pins of the CLR jumper. Now reconnect power, wait for all three lamps to flash and then remove the short on the CLR jumper. The memory is now cleared.

Pulse/Toggle Mode

The ProxLock can operate in 2 modes which are selected with the MODE jumper

Pulse Mode

This mode is selected with the MODE jumper in place (as shown in the drawing alongside). In this mode the GREEN lamp and the relay will operate for the pre-set pulse time each time a valid tag is read by the system.



An invalid tag will cause the RED lamp to light.

Toggle Mode

This mode is selected with the MODE jumper removed (as shown in the drawing alongside).



Whenever a valid tag is read the GREEN and RED lamps will change state.

While the GREEN lamp is on and the RED lamp is off, the relay is energised (the NO contact will be closed).

When the GREEN lamp is off and the RED lamp on, the relay is not energised (the NO contact will be open).

This mode can be used to switch equipment on/off or to activate/deactivate alarms using valid tags

Power-up

On first time power up of the unit the following sequence will occur:

- all 3 lamps will go on for 1 second.
- all three lamps will flash showing that the reader memory is clear.

A RED lamp flashing on its own indicates faulty memory.

Tags can now be added to the system as described in an earlier section.

Once a Master Tag has been added to the reader the power up sequence will be:

- all 3 lamps will go on for 1.5 seconds.
- the YELLOW lamp will stay on permanently.

Tag Simulator / Programmer (optional)

The Tag Simulator allows adding and removing any card/tag number from the reader memory when the tag is lost or not available. One unit can be utilised at different sites but for security reasons it will operate only in conjunction with the Master Tag.

The Tag Simulator / Programmer cannot be used to gain access. It will only operate together with the reader's MASTER tag

Battery

The unit is powered by a PP3 9V battery. Undo the 2 screws at the back of the unit to gain access to the battery.

Setting Tag Number

To set the tag number to be deleted or added:

1. Hold the On/Off button down.
2. Use the RIGHT ARROW key to move the cursor to the digit to be changed.
3. Use the UP ARROW key to change the number at the cursor.
4. Repeat the above until all the digits of the number are correct.
5. This number is stored in memory and the On/Off button may now be released.

Deleting Tags

The MASTER tag must be used to put the PSR-630 into the Delete mode.

Once in Delete mode:

1. RED lamp flashes
2. Place the Tag Simulator close to the reader
3. Hold down the On/Off button and check the displayed number
4. Press the Send button
5. The GREEN lamp will flash to verify that the selected number is deleted and then the RED lamp will continue flashing.
6. Once the tag or a group of tags have been deleted, read the Master Tag to return to the RUN state.

Adding Tags

The MASTER tag must be used to put the PSR-630 into the Add mode.

Once in Add mode:

1. GREEN lamp flashes
2. Place the Tag Simulator close to the reader
3. Hold down the On/Off button and check the displayed number
4. Press the Send button
5. The GREEN lamp will go steady and the relay will operate to verify that the selected number is added. The GREEN lamp will then continue flashing.
6. Once the tag or a group of tags have been added, read the Master Tag to return to the RUN state.

ProxLog Overview

ProxLog is a simple transaction logger for the ProxLock. Transactions are stored in non-volatile memory and can be downloaded to a PC when required. Each transaction is date and time stamped.

A ProxLog installation requires the following:

- 634-10 ProxLog Recording Module
- ProxLock Interface Cable with one DB9 connector (supplied with 634-10)
- 634-20 PC Interface Cable (ProxLog to PC cable with two DB9 connectors and 9V battery)
- 634-50 Windows ProxLog software

ProxLock Interface Cable Installation

The cable with the single DB9 connector is wired to the ProxLock base as shown below and the DB9 plugs into the ProxLog when recording transactions

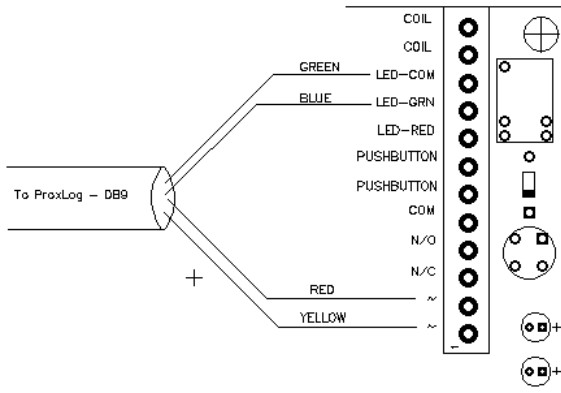

PC Interface Cable Installation

Plug the DB9 connector with the 9V battery into the Comm Port of the PC. The other end plugs into the ProxLog when downloading.

Hardware Operation

To record transactions, connect the ProxLog to the DB9 cable coming from the ProxLock.

As each tag is read it is written to the non-volatile memory of the logger.

When the memory is full (800 transactions), new transactions overwrite the oldest.

The ProxLog's 3 lamps indicate the state of the logger:

YELLOW Flashing	Normal state waiting to log transactions.
GREEN Flash	Transaction logged
RED Flash	Transaction not logged.

To download the transactions, disconnect the logger from the ProxLock and plug it into the cable connected to the PC. The YELLOW lamp will flash to indicate the unit is ready to download data. Power for the ProxLog is provided by the 9V battery connected to the PC end of the cable.

Disconnect from the cable, once downloading is complete, to save battery life.

Software Installation

Insert the disc into the drive and log on to the drive.

At the prompt type *SETUP* and follow the instructions on the screen.

To run the program, open the PROXLOG folder and double click on the PROXLOG icon.

Software Operation

Double click on the PROXLOG icon to load the program.



The Menu bar is at the top of the screen.

The Status bar is at the bottom of the screen and shows the comm port selected on the left, the Comms status in the middle and the current time on the right.

The first time the program is run, it is necessary to set the comm port used by the logger. Select *Configure|Settings* and set the correct value.

The menu items are detailed below.

Equipment Menu

The ProxLog must be connected to the PC to use any of these functions.

Equipment|Collect Transactions

Select this to start the download of transactions.

Equipment|View Current Setup

Displays the ProxLog ID code, current date, current time and the number of records in the ProxLog.

Equipment|Set ProxLog Time\Date

Displays the computer's Time and Date and also the values currently set in the ProxLog's time clock.

New values for the time and date can be set by entering required values into the Time and Date fields. To set the values to the PC's time & date, click on [Set ProxLog to PC]

To send the settings to the ProxLog select the click on [OK]

Equipment|Set ProxLog ID

Each ProxLog can have its own 3 character ID code. Use this menu to display and edit the current setting.

Configure Menu

Configure|Holders

Displays details of all holders in the database.

From the window select:

Add to enter a new holder's details.

Edit to modify an existing holder

Remove to delete a holder

Selecting either Add or Edit displays:

Add Holder [X]

Please enter the details of the new holder below

Holder Name	Tag Number	
<input type="text"/>	<input type="text"/>	
Telephone	Key Number	Date Issued
<input type="text"/>	5	18/02/98 [Calendar]
Group		
<input type="text"/>		

[?] Help [X] Cancel [✓] OK

Required fields are Holder Name, Tag Number and Group.

Enter the Tag Number printed on the tag or card.

If a Group is not selected from the drop-down box, the holder will be assigned the first defined group name.

Configure|Groups

Groups are used by Reports|Holders to group holders together.

Enter a name to define a Group.

Configure|Truncate Data

Select this function to reduce the size of the database and speed up reports.



There are three possible ways of truncating the database:

- 1.Date:- All records prior to and including the date entered are deleted.
- 2.Unregistered:- If the box is checked, all records where the holder is Unregistered (holder details not entered), are deleted.
- 3.ID:- If the box is checked, all records of the entered ProxLog ID code are deleted.

Click on [Truncate] to delete the selected records.

Configure|Settings

Registered Company Name

The name entered during installation and appearing on report headers. It may be modified.

Report Export Program

The ProxLog uses an external program to format and display reports. By default it uses NOTEPAD supplied with Windows.

To use any other program, enter it's path and filename.

Program Path

Path to the PROXLOG.EXE program. This is set by the installation program and should not require modification.

Communications Port

Comms port connected to the ProxLog. Must be setup before data may be exchanged.

Animated Opening Screen

If checked starts the program with an animated logo.

Reports Menu

Reports|Transactions

This report is a listing of all the transactions in the database. Before the report is compiled, you are given the option to apply a number of filters to the data, which can narrow down the range of transactions. The filters may be any combination of Start Date, End Date and ProxLog ID.

To use a filter, click on the filter check box and enter the required value. Only records that match the filter parameters appear in the report.

Click OK to create the report.

Reports|Holders List

Creates a report of Holders in the database.

Holders can be printed by group by checking the Group box and selecting a Group name from the drop down list.